

# T700 AIR

## PORTABLE TRAMP OIL REMOVAL UNIT

- **POWERED BY COMPRESSED AIR**
- **REMOVES TRAMPOIL CONTAMINATION**
- **EXTENDS COOLANT LIFE**
- **REDUCES COOLANT COSTS – REDUCED CONSUMPTION AND REDUCED DISPOSAL VOLUMES**
- **INCREASED MACHINE TOOL EFFICIENCY / PRODUCTIVITY**
- **REDUCES BACTERIAL GROWTH**
- **IMPROVED OPERATOR CONDITIONS - IMPROVED HEALTH AND SAFETY**
- **MINIMAL RUNNING COSTS**
- **ONE UNIT CAN SERVICE AN ENTIRE WORKSHOP**

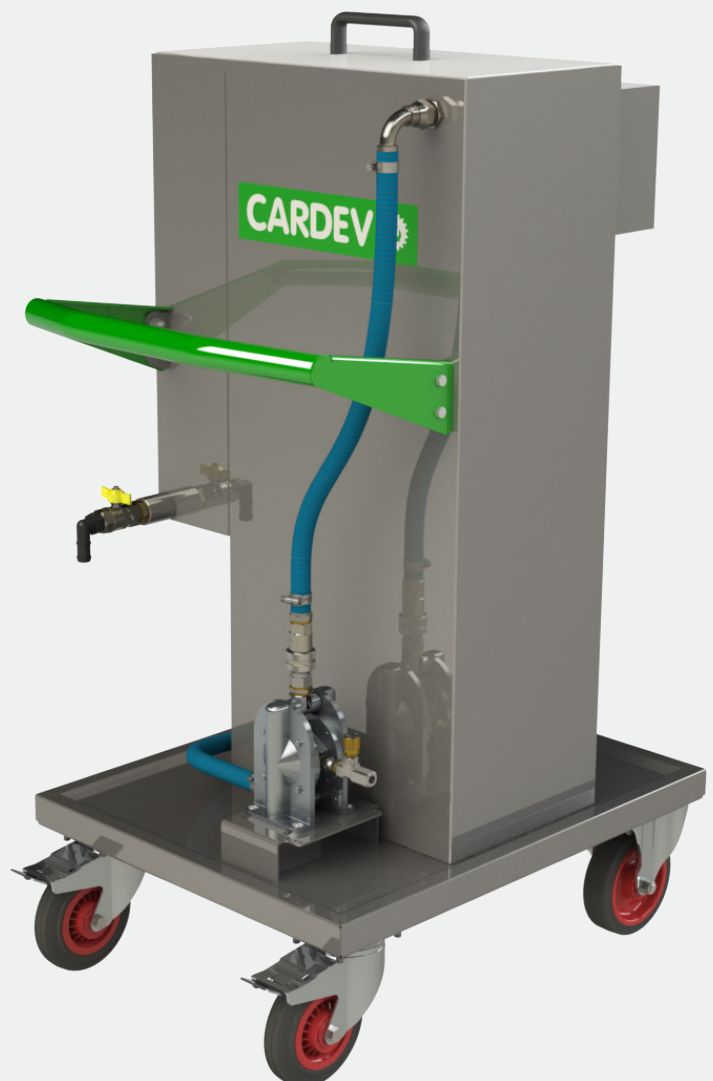

COMPRESSED AIR  
SUPPLY REQUIRED

# T700 AIR - PORTABLE TRAMP OIL REMOVAL UNIT

## DIMENSIONS

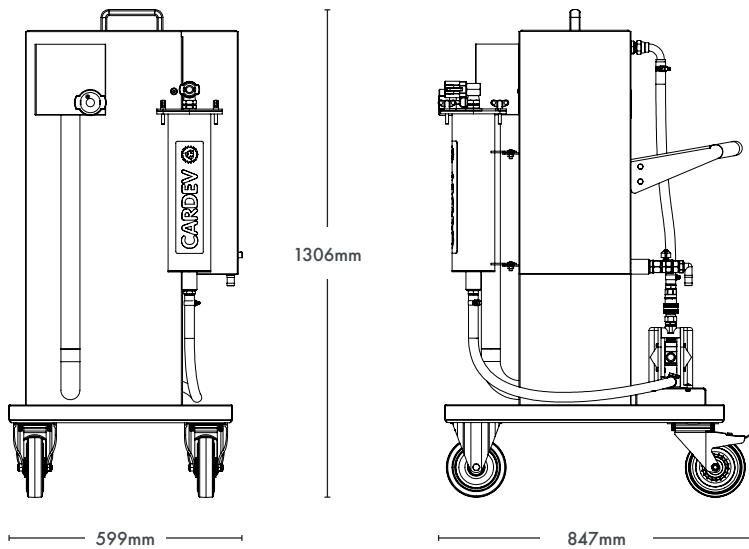

## COOLANT SAMPLES



## FEATURES

- PORTABLE STAINLESS STEEL CONSTRUCTION
- MINIMAL SERVICING REQUIRED - NO CONSUMABLE PARTS
- REUSABLE BAG FILTER
- ONE UNIT CAN SERVICE AN ENTIRE WORKSHOP
- UNATTENDED OPERATION
- EASY TO USE - MINIMAL SETUP AND NO "LEVELLING" REQUIRED
- UNIVERSAL APPLICATION - WORKS ON ANY COOLANT SUMP

## RESULTS

- REMOVES TRAMP OIL CONTAMINATION
- EXTENDS COOLANT LIFE
- REDUCES COOLANT COSTS - REDUCED CONSUMPTION AND REDUCED DISPOSAL VOLUMES
- INCREASED MACHINE TOOL EFFICIENCY / PRODUCTIVITY
- REDUCES BACTERIAL GROWTH
- IMPROVED OPERATOR CONDITIONS - IMPROVED HEALTH AND SAFETY

## TECHNICAL SPECIFICATIONS

FLUID FLOW RATE (L/M)	12 L/M		
POWER	AIR OPERATED		
DIMENSIONS (MM)	H: 1306	W: 599	L: 847
WEIGHT (KG)	100 KG		
CONNECTIONS	INLET - 3/4" LANCE    OUTLET - 3/4" LANCE		

**ETL FLUID EXPERTS LTD**  
GRIMBALD CRAG ROAD, KNARESBOROUGH  
NORTH YORKSHIRE, HG5 8PY

T +44 (0)1423 522911    E SALES@ETLFE.COM

[WWW.ETLFLUIDEXPERTS.COM](http://WWW.ETLFLUIDEXPERTS.COM)

THE SPECIFICATION AND PHOTOGRAPHY IS FOR REFERENCE ONLY AND MAY BE SUBJECT TO CHANGE.  
V04-22-04-24-GB / © ETL FLUID EXPERTS LTD. ALL RIGHTS RESERVED.

