

T700

PORTABLE TRAMP OIL REMOVAL UNIT

- **CLEAN, TRAMP OIL FREE COOLANT**
- **INCREASED COOLANT LIFE – REDUCED COOLANT COSTS**
- **REDUCED DISPOSAL COSTS**
- **REDUCED MACHINE DOWNTIME – CLEAN COOLANT WHILST THE MACHINE IS IN OPERATION**
- **IMPROVED OPERATOR CONDITIONS - REDUCED OIL MIST, REDUCED BACTERIAL GROWTH, COOLANT ODOUR REDUCED**
- **PROGRESSIVE CAVITY PUMPSET - 110V & 230V (50/60HZ) OPTIONS AVAILABLE**

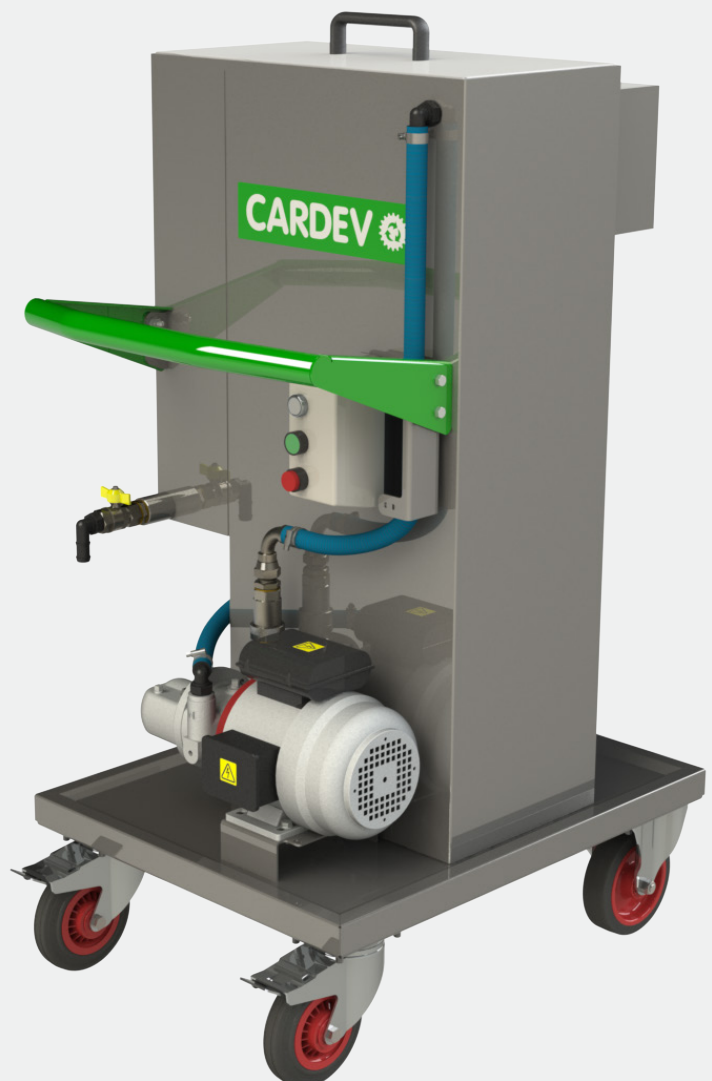

VOLTAGE OPTIONS
110V - 230V

T700 - PORTABLE TRAMP OIL REMOVAL UNIT

DIMENSIONS

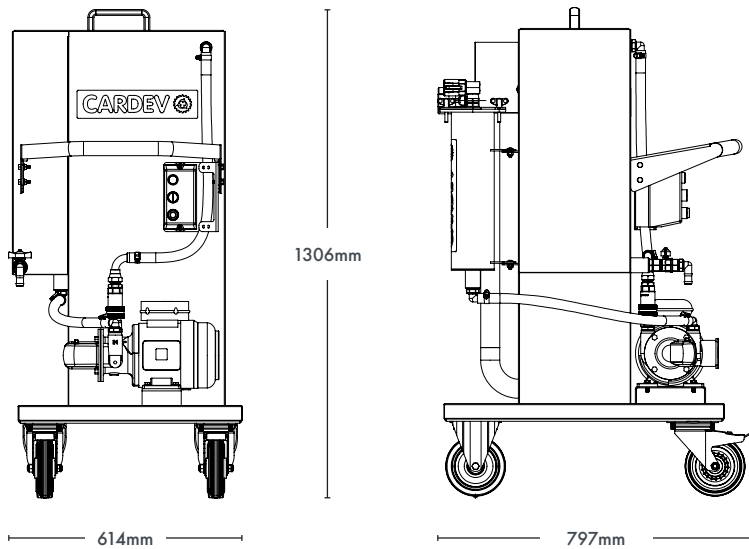

COOLANT SAMPLES



FEATURES

- PORTABLE STAINLESS STEEL CONSTRUCTION
- MINIMAL SERVICING REQUIRED - NO CONSUMABLE PARTS
- REUSABLE BAG FILTER
- ONE UNIT CAN SERVICE AN ENTIRE WORKSHOP
- UNATTENDED OPERATION
- UNIVERSAL APPLICATION - WORKS ON ANY COOLANT SUMP

RESULTS

- REMOVES TRAMP OIL CONTAMINATION
- EXTENDS COOLANT LIFE
- REDUCES COOLANT COSTS - REDUCED CONSUMPTION AND REDUCED DISPOSAL VOLUMES
- INCREASED MACHINE TOOL EFFICIENCY / PRODUCTIVITY
- REDUCES BACTERIAL GROWTH
- IMPROVED OPERATOR CONDITIONS - IMPROVED HEALTH AND SAFETY

TECHNICAL SPECIFICATIONS

FLUID FLOW RATE (L/M)	12 L/M
VOLTAGE OPTIONS	110V - 230V
CURRENT DRAW	≤ 3.5AMPS - ≤ 2.0AMPS
DIMENSIONS (MM)	H: 1306 W: 614 L: 797
WEIGHT (KG)	105 KG
CONNECTIONS	INLET - 3/4" LANCE OUTLET - 3/4" LANCE

ETL FLUID EXPERTS LTD
GRIMBALD CRAG ROAD, KNARESBOROUGH
NORTH YORKSHIRE, HG5 8PY

T +44 (0)1423 522911 E SALES@ETLFE.COM

WWW.ETLFLUIDEXPERTS.COM

THE SPECIFICATION AND PHOTOGRAPHY IS FOR REFERENCE ONLY AND MAY BE SUBJECT TO CHANGE.
V08-26-03-24-GB / © ETL FLUID EXPERTS LTD. ALL RIGHTS RESERVED.

